

**INTELLIGENT BLDC electronic**

**Programmable in BASIC**

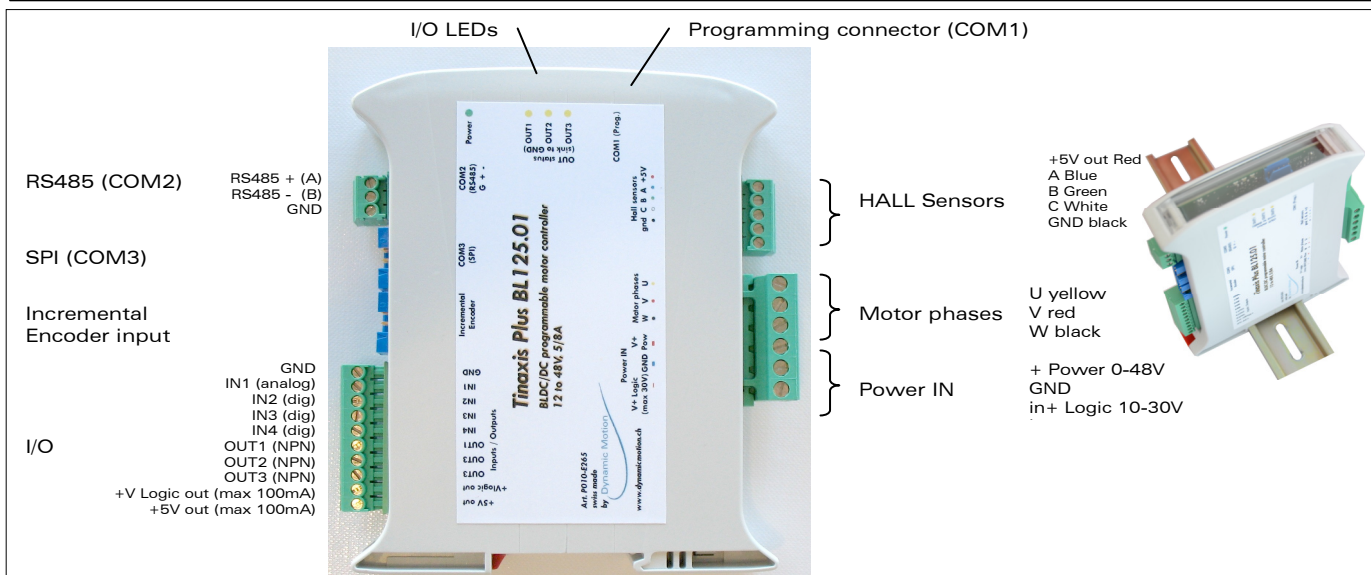

**Overview**

The **Tinaxis BL125 INTELLIGENT controller** is a powerful motor driver, programmable in **BASIC**, includes **32bit ARM processor**. The BL125 is the housing version of BL120. **48V- 5A continuous, up to 8 A peak (200W / 360W)**

- PWM amplifier: 2, 4 quadrants, block commutation, with brake
- High performance multiple PID controllers, predictive module
- Speed 0 to 100'000 RPM
- Rotor detection: Hall sensors
- Programmable in BASIC (12kB program flash), configuration wizard for easy use
- 50 MHz, 32 bit microcontroller (ARM)
- 4 inputs (1 analog, 3 digital, with time counting capability: 20ns resolution)
- 3 outputs Open collector NPN, 100mA 35V
- 3 serial connectors: RS232 (TTL levels), RS485, SPI
- Encoder input: A/B + Index (SSI possible on SPI)
- Can drive 1 BLDC or 2 DC motors or 3 solenoids or 1DC and 1 solenoid

Parameter (summary)	unit	value
1 Supply voltage POWER and LOGIC separated	V	Power: 0-48V / Logic 8-30V
2 Driver current (continuous / peak) (On high values, be careful of temperature elevation)	A	5 / 8
3 Input current when motor OFF	mA	30 to 100 (depend on voltage)
4 General purpose inputs: 1 analog input, 0-25V with 25mV resolution, impedance to GND: ~30kOhm 3 digital. In timer mode, time resolution of 20ns An input not connected is low levelled (<100mV or logical 0)		
5 General purpose outputs: 3 digital outputs, open collector to GND, max 100mA 35V, visualized by LEDs		
8 PWM frequency	kHz	1 to 60
9 Ambient temperature range for 100% of max power*	°C	-10 to 50
10 Ambient temperature range for 50% of max power*	°C	-10 to 75
11 Response time on input change	ms	<2.5
12 Embedded safety protections: Over temperature, over current (software), low current polarity inversion, ESD in wires, short circuited outputs		
13 Safety precautions: be sure to avoid these parameters during storage and use: Water or metallic particles projections, shocks, over voltage, reversed voltage		
14 Start-up initialisation time (system boot): < 300 ms		
15 Communication, hardware description: COM1 (UART TTL, to USB or RS232 via adapter) 100 to >500000 bps COM2 RS485 with fail safe, no terminal resistor. 100 to >500000 bps COM3 SPI (accessories connector) Optional MODBUS ASCII or RTU (binary)		
15 Communication, software description: COM1 and COM2: DM-Remote, DM-binary (slave or master) COM3: to connect SSI encoder(s), I/O module, display module		
16 Movement: Open loop voltage mode – closed loop speed control with ramps – closed loop positioning with trajectory generation – cam generation (optional) - brake mode – free wheel mode		
* depend on the cooling conditions		

This specification is subject to change without prior notice

Dynamic Motion SA  
105, rue Fritz Courvoisier  
2300 La Chaux-de-Fonds  
Switzerland

welcome@dynamicmotion.ch  
www.dynamicmotion.ch  
Phone: +41 32 968 64 50  
Fax: +41 32 968 64 51

**Software**

Custom motion software can be written by the user and download to the unit from a user friendly Windows software available at Dynamic Motion, through a RS232 or USB cable provided by Dynamic Motion, or through a long distance RS485. Thanks to the BASIC programming, any kind of sequence and behaviour can be programmed with a

minimum effort, ensuring a reliable operation and fast engineering.

The user can access to the motion parameters, I/O, communication parameters and various other parameters like temperature or timers. Tinaxis BL120 offers the extended parametric motion calculator.

**Driver detailed electrical characteristics****Power connector**

Pin	Function	Range
1	Logic +	8-30V
2	GND	
3	Power +	0-48V

**GND** = negative voltage, common to Power, Logic, I/O

**V + Power** = Supply of the amplifier bridge that power the motor phases. Note: V+ power works from 0V

**V + Logic** = Supply of the internal circuits (microprocessor, LCD, IO, ...)

Both V+ can be connected together, or separate. Therefore it is possible to connect the power through a safety relay, without affecting the software execution.

Connector type: 3.5mm pitch, terminal block, for up to 1.5 mm<sup>2</sup>

**I/O connector (Inputs – Outputs)**

Pin	Function	Description
1	+5V out	Max 100mA, usage: only to supply low current devices, as switches, leds, potentiometers, ...
2	+V Logic out	Voltage to connect external low power devices that are connected to the board. This output is not protected, not short-circuit tolerant. Max current: 100mA.
3	Out3	NPN output (see below)
4	Out2	NPN output
5	Out1	NPN output
6	IN4	Digital
7	IN3	Digital
8	IN2	Digital
9	IN1	Analog input: 10 bits with oversampling
10	GND	Use it to reference the I/O. Do not supply from this pin. Internally connected to power GND

The outputs are "Open collector" NPN transistors, with over-current protection circuitry. In software, a level 0 makes the transistor not conducting, and a level 1 makes them conducting up to 100mA in total for the 4 channels. When an over-current is detected, the outputs are disabled up to the next reset (power off of logic supply). The state of the outputs are shown with the LED

Tips: how to make it compatible with PNP logic?

Answer: use a pull-up resistor, to force the voltage to a higher value when the transistor is not active. The value of that resistor can be between 4.7k and 10k.

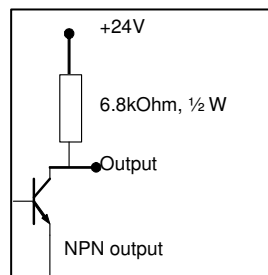
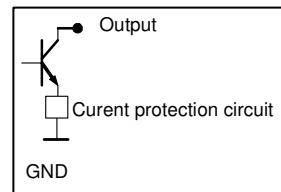
**Programming connector**

The 5 pin connector may be used for downloading the BASIC software and for remotely control the electronic.

**Encoder connector**

6 PIN Micromatch type

Pinout:

1. GND
2. A
3. B

This specification is subject to change without prior notice

Dynamic Motion SA  
105, rue Fritz Courvoisier  
2300 La Chaux-de-Fonds  
Switzerland

welcome@dynamicmotion.ch  
www.dynamicmotion.ch  
Phone: +41 32 968 64 50  
Fax: +41 32 968 64 51

4. Index
5. Chip Select (not used with incremental encoders, only for SSI encoders)
6. +5V (max. 40mA)

**SPI connector**

6 PIN Micromatch type

Pinout:

1. GND
2. CLK
3. RX
4. TX
5. Chip Select
6. +5V (max. 40mA)

## Driver software characteristics

For a complete documentation, please refer to the Software manual 3.x. This section is a summary of the most used options

**Programming environment**

The minimum requirement is:

A computer with a serial connexion, a text editor, a terminal software for downloading and a cable to connect the motor to the computer.

Dynamic Motion provides the following components:

- Free (GNU) text editor with special syntax coloration add-on for Dynamic Motion BASIC language
- Free Dynamic Motion Communication Software that works under Windows XP
- 9 pin RS232 adaptor to the 5 pin communication connector, with 1.8m prolongation cable
- USB – RS232 converter cable (needed if your computer does not have RS232 connector)

**Programming language**

- The software that runs inside the controller is **Dynamic Motion BASIC**.
- To remotely control the motor, a set of **REMOTE commands** is available.

**Dynamic Motion BASIC summary**

Instructions	Expression operators	Comparison operators
IF-THEN-ELSE	(form: variable = expression)	=
FOR-TO-NEXT	+	<
GOSUB-RETURN	-	>
GOTO	*	<> (not equal)
PRINT	/	<= (smaller or equal)
PAUSE	^ (power)	>= (bigger or equal)
END	% (remaining of a division)	
	()	

Variables, registres	Special	Numbers
<i>user variables:</i> A, B, ...Y, Z	' (line comment)	Line labels: 0 to 9999999
<i>Predefined variables:</i> see Dynamic Motion BASIC detailed description	" (text string descriptor)	Numbers: signed integer in decimal notation, 32bit
<i>Example:</i> SPEED	, ; (argument separators)	(range: from -2'147'483'648 to + 2'147'483'647)

**Remote language**

Motion Instructions	System Instructions	Programming tools
JG (jog, set speed)	SB (Stop Basic execution)	PR (Print the BASIC software currently in Flash memory)
MT (move to, absolute position)	TB (Start Basic execution)	PC (Print configuration)
MB (move by, relative move)	RB (RESET Basic execution)	UL (Upload BASIC software)
MD (mode: brake, speed, ...)	VA (variable get or change)	
DS (Disable motor)	RV (reset all variables to default)	
BR (Brake)		

Usage example: jg 1200<sup>enter</sup>: set the jog speed to 1200RPM

**Most used variables**

Motion variables	Usage
MODE	0: auto; 1: brake; 2: not powered; 4: open loop; 6: speed regulation; 8: positioning
JOG	Set the speed regulation value (unit: RPM)
TARGET	Set the position to reach in positioning mode (unit: encoder increment, 1024 = 1 rev.)
MOT_V	Motor voltage: can be read in any modes. Set voltage in open loop. (Unit: mV)
ACC, DEC	Acceleration and deceleration value that regulation must follow
M_SP_P, M_SP_N	Max speed in positive and negative direction in positioning mode
SPEED, POS_HAL	Value of the measured speed and position (unit: RPM and HALL sensor increment)
IN1, IN2, ...IN4	Value of the voltage measured on the 5 inputs (unit: mV)
OUT1, ... OUT3	Set the state of the outputs (0 = not conducting, 1 = conducting)
V_POW, I_MOT	Measured voltage of power supply, measured motor current (unit: mV and mA)
TEMPER	Temperature of the board (unit: 1/1000 °Celsius)
TIME	Time in seconds since last power-up (68 year counting)

This specification is subject to change without prior notice

Dynamic Motion SA  
105, rue Fritz Courvoisier  
2300 La Chaux-de-Fonds  
Switzerland

welcome@dynamicmotion.ch  
www.dynamicmotion.ch  
Phone: +41 32 968 64 50  
Fax: +41 32 968 64 51

TIME_U1, TIME_U2 TIME_D1, TIME_D2 PID1_P, PID1_I, PID1_D ...	Timer counting up from 0 to $\sim 2 \cdot 10^9$ , stopped when value is neg. (Unit: millisecond) Timer counting down to 0, from any positive value (Unit: millisecond) PID regulator factors (used in any closed loop modes) <i>See the detailed documentation for complete description</i>
--	--

**Software example**

```

100      'line label of infinite loop
      if in1 > 2000 then gosub 200 'jump to subroutine at label 200 if voltage on IN1 is > 2.0V
      else jog = 0 'stop motor
goto 100 'back to the beginning if infinite loop
200     jog = 2500 'set speed to 2500RPM
      pause 10000 'wait 10.0 second
return  'come back from subroutine
    
```

**Commutation table**

In the case that the HALL sensor polarity is positive:

Step nr (register HALL_N)	0	1	2	3	4	5
Hall sensor A	0	0	0	1	1	1
Hall sensor B	0	1	1	1	0	0
Hall sensor C	1	1	0	0	0	1
Phases voltage CW						
U	hZ	GND	GND	hZ	+	+
V	GND	hZ	+	+	hZ	GND
W	+	+	hZ	GND	GND	hZ
Phases voltage CCW						
U	hZ	+	+	hZ	GND	GND
V	+	hZ	GND	GND	hZ	+
W	GND	GND	hZ	+	+	hZ

Legend:

0= low voltage level (0V), 1= level high (5V)

hZ = high impedance, + = PWM variable voltage, GND= connected to GND

**Typical connections**

The example below shows the minimum connections if the Tinaxis board has been programmed before (using onboard connector COM1, an adaptor cable P000-034, and the free software "Dynamic Motion Programming Suite").

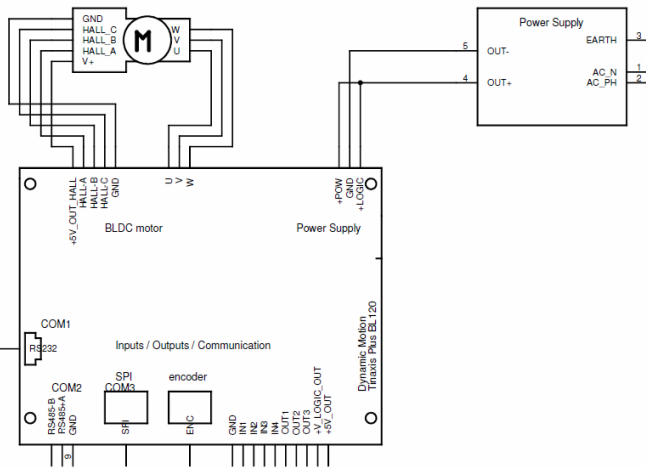

**Ordering information**

Désignation	Article
1 Tinaxis Plus BL125.01	P010-E265

**Custom versions possible**

Contact person: Bernard Vaucher / direct phone +41 32 968 64 54

This specification is subject to change without prior notice

Dynamic Motion SA  
105, rue Fritz Courvoisier  
2300 La Chaux-de-Fonds  
Switzerland

welcome@dynamicmotion.ch  
www.dynamicmotion.ch  
Phone: +41 32 968 64 50  
Fax: +41 32 968 64 51